

# Serum Soluble Bone Turnover Biomarkers in Psoriatic Arthritis and Psoriatic Spondyloarthropathy

Deepak R. Jadon, Alison L. Nightingale, Neil J. McHugh, Mark A. Lindsay, Eleanor Korendowych, and Raj Sengupta

**ABSTRACT.** Because psoriatic arthritis (PsA) is an inflammatory disease of joints, serum soluble biomarkers specific for chronic joint and bone inflammation may predict future disease severity and response to therapy, thereby informing stratified medicine approaches. The objectives of our systematic review were to determine whether serum soluble bone and cartilage turnover biomarkers are (1) associated with PsA or psoriatic spondyloarthropathy; and (2) associated with disease activity, disease severity, or clinical phenotype. Ten studies met eligibility criteria. Matrix metalloproteinase (MMP)-3, Dickkopf (DKK)-1, macrophage colony-stimulating factor (M-CSF), crosslinked telopeptide of collagen-1, and tumor necrosis factor-related apoptosis-inducing ligand were associated with PsA, with equivocal results for osteoprotegerin (OPG) and bone alkaline phosphatase (ALP). MMP-3, DKK-1, M-CSF, CII:C2C (ratio of cartilage degradation vs byproduct formation), and possibly OPG were associated with PsA independently of psoriasis. C1-2C (a neoepitope released when type 2 cartilage is degraded by collagenases) was associated with both tender and swollen joint counts, and bone morphogenetic protein-4 with patient global assessment of disease, pain score, and the Bath Ankylosing Spondylitis Disease Activity Index. Bone ALP was associated with disease activity. M-CSF and receptor activator of nuclear factor- $\kappa$ B ligand were associated with several plain radiographic features. No studies have investigated biomarker associations specifically with axial PsA. (J Rheumatol First Release Nov 1 2014; doi:10.3899/jrheum.140223)

## Key Indexing Terms:

ARTHRITIS PSORIATIC PSORIATIC SPONDYLOARTHRITIS  
BIOLOGICAL MARKERS MATRIX METALLOPROTEINASE DICKKOPF-1

Psoriatic arthritis (PsA) is a chronic inflammatory musculoskeletal disorder with characteristic patterns of peripheral and axial joint inflammation and extraarticular manifestations that can include skin psoriasis, psoriatic nail disease, enthesitis, dactylitis, or uveitis. As such, candidate serum soluble biomarkers specific for chronic joint and bone inflammation may predict future disease severity and response to therapy, thereby informing stratified medicine approaches. However, identifying and monitoring biomarkers in PsA is difficult because of the heterogeneity of

PsA disease. In PsA, bone loss can occur in the form of bone erosion, osteolysis, and bone mineral density (BMD) loss<sup>1</sup>. Bone formation can occur in the form of osteoproliferation, ankylosis, and syndesmophytes.

Several bone and cartilage turnover biomarkers might be of interest in PsA. Some directly cause bone resorption through their enzymatic or cytokine properties, e.g., matrix metalloproteinase (MMP)-3 enzymatically degrades the extracellular matrix of bone and cartilage<sup>2</sup>. Osteoprotegerin (OPG) is a glycoprotein secreted by osteoblasts and stromal cells, acting as a decoy receptor to receptor activator of nuclear factor- $\kappa$ B ligand (RANKL), thereby inhibiting osteoclastogenesis, resulting in reduced bone resorption. Others are byproducts of bone resorption, thereby acting as markers of the process, e.g., crosslinked telopeptide of collagen (CTX)-1 is the product of excess metalloproteinase degradation of type 1 collagen. There are several byproducts of cartilage turnover: C2C and C1-2C are neoepitopes that are released when type 2 cartilage is degraded by collagenases; CII is released during procollagen 2 synthesis; and CII:C2C is the ratio of cartilage degradation versus byproduct formation<sup>3</sup>.

Although there have been several editorial review

From the Royal National Hospital for Rheumatic Diseases, and the University of Bath, Bath, UK.

Supported by an unrestricted educational grant from Pfizer Pharmaceuticals.

D.R. Jadon, MRCP, Research Fellow, Rheumatology; E. Korendowych, FRCP, Consultant Rheumatologist; R. Sengupta, FRCP, Consultant Rheumatologist, Royal National Hospital for Rheumatic Diseases; A.L. Nightingale, PhD, Research Fellow; M.A. Lindsay, PhD, Professor, Pharmacy and Pharmacology, University of Bath; N.J. McHugh, FRCP, Consultant Rheumatologist, Royal National Hospital for Rheumatic Diseases, and the University of Bath.

Address correspondence to Dr. D.R. Jadon, Department of Rheumatology, Royal National Hospital for Rheumatic Diseases, Upper Borough Walls, Bath, BA1 1RL, UK. E-mail: jadondr@yahoo.com

Accepted for publication September 2, 2014.

Personal non-commercial use only. The Journal of Rheumatology Copyright © 2014. All rights reserved.

articles, to the best of our knowledge, there have been no systematic reviews published on the clinical and prognostic value of serum soluble bone turnover biomarkers in PsA. The objectives of this systematic review were to determine whether serum soluble bone and cartilage turnover biomarkers are (1) associated with PsA or psoriatic spondyloarthritis (PsSpA); and (2) associated with disease activity, disease severity, or clinical phenotype in PsA cases versus healthy controls, and PsA versus cutaneous psoriasis without arthritis (PsC).

## MATERIALS AND METHODS

Methods of analysis and eligibility criteria were specified in advance and documented in an *a priori* protocol. Our study aligns with “The PRISMA Statement for Reporting Systematic Reviews and Meta-Analyses of Studies That Evaluate Health Care Interventions”<sup>4</sup>.

**Inclusion criteria.** We included cohort, case-control, cross-sectional studies and randomized, controlled trials published in the form of a journal paper, journal abstract, or conference abstract that compared the serum concentration of bone and cartilage turnover biomarkers in PsA cases to that in healthy controls, with or without an additional PsC comparator group.

Study participants with PsA must have fulfilled classification criteria for PsA (Classification for Psoriatic Arthritis<sup>5</sup>, or Moll and Wright<sup>6</sup>) or PsSpA<sup>7</sup>.

The following bone and cartilage turnover biomarkers were included [as defined in Medical Subject Headings (MeSH), Emtree, or key terms]: OPG, MMP-3, sclerostin, Dickkopf (DKK)-1, bone alkaline phosphatase (ALP), osteocalcin (OC), macrophage colony-stimulating factor (M-CSF), RANKL, collagen type II, extracellular matrix proteins, glycoproteins, procollagen, amino-terminal propeptide of procollagen type III (PIIINP), CTX-1, tumor necrosis factor-related apoptosis-inducing ligand (TRAIL), bone morphogenetic protein (BMP), and cartilage oligomeric matrix protein (COMP).

Outcome variables were (1) peripheral and/or spinal involvement: clinical symptoms, radiographic disease; (2) disease severity as measured by axial and/or peripheral radiographic disease; and (3) disease activity: tender joint counts, swollen joint counts, Bath Ankylosing Spondylitis Disease Activity Index (BASDAI), Bath Ankylosing Spondylitis Functional Index (BASFI), Bath Ankylosing Spondylitis Metrology Index, enthesitis, C-reactive protein (CRP), composite scores, and other outcome measures.

**Exclusion criteria.** We excluded studies without a healthy control (HC) group. We excluded studies in which participants were being treated with biological agents, because tumor necrosis factor inhibitors<sup>8,9,10</sup>, but not conventional disease-modifying antirheumatic drugs (DMARD)<sup>10,11</sup>, have been reported to directly influence serum bone and cartilage turnover biomarkers<sup>12</sup>, thereby confounding results when comparing HC with PsA cases.

**Searches.** The search date was February 1, 2014. The following databases were searched using key indexing terms: Medline (1950–present), Embase (1974–present), and the Cochrane Controlled Trials Register (1993–present). The following MeSH, Emtree, or key term stems were used: arthritis, psoriatic, psoriatic spondyloarthritis, biological markers, and bone turnover markers. No language restrictions were applied to publications.

The reference lists of all papers fulfilling inclusion criteria and all review articles were scrutinized for any references not identified in the original database search, but still meeting the inclusion criteria. Two key authors (VC, OF) were contacted to determine whether any important unpublished or unindexed papers (e.g., conference proceedings) should be screened.

**Study selection.** Two reviewers (DJ, RS) independently assessed abstracts for inclusion in the review. Where there was disparity in opinion, the full

paper was obtained and consensus for inclusion or exclusion was reached (DJ, RS). An assessment was made at this point for potential publication bias or selective reporting within studies. Two reviewers (DJ, AN) independently extracted data from the papers onto a standardized data-extraction Excel spreadsheet that was initially pilot-tested. The papers were critically appraised using the Critical Appraisal Skills Programme toolkit<sup>13</sup> for cohort and cross-sectional studies, including sources of bias, both at study and outcome level. DJ and AN reached consensus on the data for use in the subsequent analyses.

**Synthesis of results.** The primary summary measure was OR for serum biomarker levels in PsA versus healthy controls or PsA versus PsC, including p values for the analyses. The secondary summary measures were OR or Spearman rho correlation coefficient for clinical outcomes in PsA versus healthy controls or PsA versus PsC, including 95% CI and p values for the analyses.

We initially intended to combine the results of different studies mathematically as a metaanalysis, including tests for heterogeneity. However, because of the differing methods used in the included studies (cohorts, laboratory techniques using ELISA or immunoassays with different reference ranges, statistical analyses) and a lack of homogeneity in the reporting of results, it was not possible to combine the results of different studies statistically. Therefore, we have reported the results of the studies quantitatively, without metaanalysis.

## RESULTS

**Search results.** There were 155 unique studies identified; 10 of these met the eligibility criteria and were included in the systematic review. Two papers<sup>14,15</sup> that met inclusion criteria were unobtainable from several libraries (including the British Library) or on contacting the first authors, and insufficient detail of results were provided in the abstract to allow inclusion in the systematic review. Four papers were excluded because they did not have a healthy control group for comparison with the PsA group<sup>16,17,18,19</sup>. Eight papers were excluded because the PsA cases were using biological agents, and either did not have a healthy control comparator group or did not provide prebiological initiation biomarker data<sup>8,9,10,12,19,20,21,22</sup>. The remaining 131 articles were excluded because they did not fulfil several eligibility criteria. No further articles were identified on scrutinizing the reference list of included articles or by the recommendation of the 2 key authors (VC, OF).

Figure 1 details the flow of study selection in the systematic review, and Table 1 summarizes the characteristics of the 10 studies meeting the eligibility criteria of the systematic review.

**Comparison of biomarkers levels in PsA cases versus healthy controls.** The results of comparisons between biomarkers levels in PsA cases versus healthy controls are shown in Table 2. The serum concentration of several biomarkers (MMP-3, DKK-1, M-CSF, CTX-1, and TRAIL) was significantly higher in PsA versus healthy controls, whereas the serum concentration was not significantly different in PsA versus healthy controls for RANKL, BMP, OC, PIIINP, COMP, C1-2C, and CPII:C2C. The results for OPG and ALP were equivocal.

**Comparison of biomarker levels in PsA cases versus PsC**

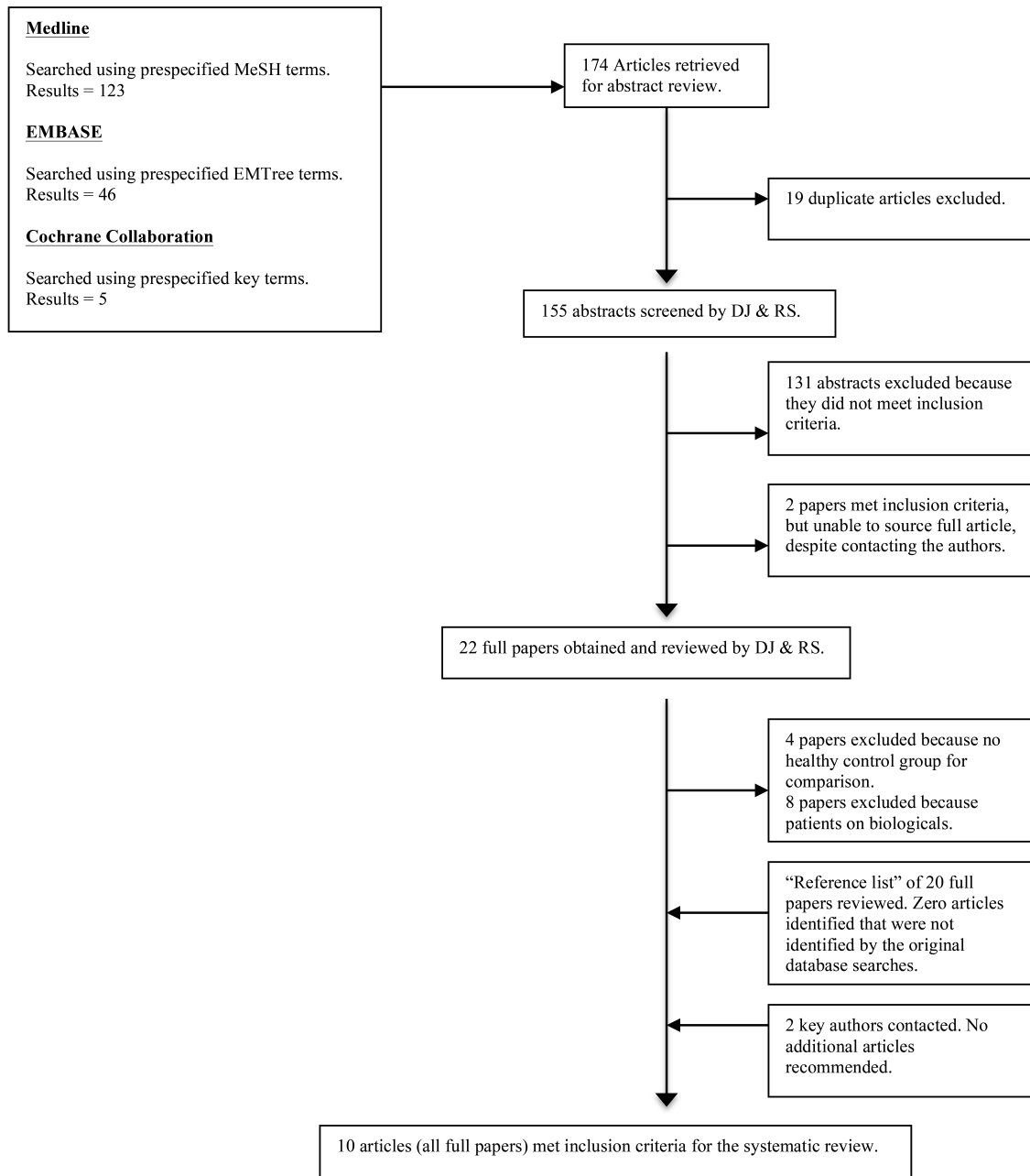

Figure 1. Study selection in the systematic review. MeSH: Medical Subject Headings; DJ and RS: independent reviewers.

cases. The results of comparisons between biomarkers levels in PsA versus PsC are given in Table 3. The serum concentration of MMP-3, DKK-1, M-CSF, and CII:C2C was significantly higher in PsA versus PsC. The results for OPG were equivocal.

*Association of biomarker levels with demographic variables.* Franck and Ittel<sup>28</sup> demonstrated 2 biomarkers to be higher in male versus female patients with PsA: ALP (mean serum concentration 137 U/l in males vs 91 U/l in

females,  $p < 0.05$ ) and OC (mean serum concentration 3.62 ng/ml in males vs 2.28 ng/ml in females,  $p < 0.05$ ). However, Hofbauer, *et al*<sup>25</sup> did not corroborate the findings for OC, demonstrating OC levels to be no different in male and female patients with PsA (23.7 ng/ml in males vs 23.1 ng/ml in females,  $p = 0.82$ ). However, the populations of the 2 studies differed, with Hofbauer, *et al* excluding patients treated with DMARD or corticosteroids and taking fasting blood samples, whereas Franck and Ittel took unfasted

Table 1. Characteristics of the 10 studies meeting eligibility criteria of the systematic review.

Authors	Journal	Country	Design	Setting	Case Selection	Classification Criteria Used	HC	PsA	PsC	Other Cohorts	Mean Age, Yrs	Mean Disease Duration, Yrs	Matching	Male:female Ratio
Chandran, <i>et al</i> 2010 <sup>10</sup>	Rheumatology	Canada	Prospective single center	OPD	Age and sex matching	CASPAR	26	26	26	—	46.9	13.4	Age and sex	12:14
Dalbeth, <i>et al</i> 2010 <sup>11</sup>	Arthritis Research Therapy	New Zealand	Prospective single center	OPD	NS	CASPAR	12	38	10	—	50	10	Age and ethnicity	More females in HC group
Grcevic, <i>et al</i> 2010 <sup>23</sup>	Journal of Rheumatology	Croatia	Prospective single center	OPD	NS	Moll and Wright	25	23	—	27 AS, 49 RA, 17 OA	53.5	9.9	Age	11:12
Shibata, <i>et al</i> 2009 <sup>24</sup>	Journal of Dermatological Science	Japan	Prospective dual center	OPD	NS	Bennett	11	16	15	9 RA	51.8	—	Age and sex	11:5
Hofbauer, <i>et al</i> 2006 <sup>25</sup>	Rheumatology	Germany	Prospective single center	OPD	NS	CASPAR	90	116	—	—	52	—	—	59:57
Grisar, <i>et al</i> 2002 <sup>26</sup>	Journal of Rheumatology	Austria	Prospective	OPD	NS	ESSG	41	23	—	30 AS, 10 ReA	45.2	—	NS	17:6
Ribbens, <i>et al</i> 2000 <sup>27</sup>	Annals of the Rheumatic Diseases	Belgium	Prospective single center	OPD	NS	Moll and Wright	96	18	—	126 RA, 37 OA, 28 AS, 9 other	46	—	Sex	9:9
Franck and Ittel 2000 <sup>28</sup>	Rheumatology International	Germany	Prospective single center	OPD	Consecutive OPD attendees	Moll and Wright	50	32	17	—	45	—	Age and sex	21:11
Sharif, <i>et al</i> 1996 <sup>29</sup>	Annals of the Rheumatic Diseases	UK	Prospective single center	OPD	NS	Baker 1963	16	12	—	40 OA, 30 RA	50.6	7.5	—	10:2
Magaro, <i>et al</i> 1989 <sup>30</sup>	Clinical Rheumatology	Italy	Prospective single center	IPD	NS	NS	25	25	—	25 RA	50.3	11.3	Age and sex	Females only

HC: healthy control; PsA: psoriatic arthritis; PsC: cutaneous psoriasis without arthritis; OPD: outpatient department; CASPAR: Classification for Psoriatic Arthritis criteria; AS: ankylosing spondylitis; RA: rheumatoid arthritis; OA: osteoarthritis; ESSG: European Spondyloarthropathy Study Group; ReA: reactive arthritis; IPD: inpatient department; NS: not stated.

samples and included patients treated with DMARD and corticosteroids. Similarly, the association between OPG levels and sex were conflicting, with higher levels in females versus males in the study by Hofbauer, *et al* (6.7 pmol/l in females vs 2.09 pmol/l in males,  $p = 0.001$ )<sup>25</sup>, but no difference by sex in the smaller study by Dalbeth, *et al* (mean serum concentrations or  $p$  values not stated)<sup>11</sup>. No correlation has been reported between sex and DKK-1<sup>11</sup>, M-CSF<sup>11</sup>, RANKL<sup>11</sup>, PIIINP<sup>25,29</sup>, or cross-laps<sup>25</sup>.

No association has been reported for PIIINP and age of patient with PsA at the time of sampling ( $p = 0.925$ )<sup>11,29</sup>, DKK-1, RANKL, M-CSF, or OPG ( $p$  values or Spearman rho correlations not stated) and body weight in kg<sup>11</sup>.

*Association of biomarker levels with clinical variables.* Three studies investigated the association between PsA disease duration and serum biomarkers<sup>26,28,29</sup>. However, none of the studies defined whether duration was analyzed as a continuous or categorical variable. Disease duration was positively associated with serum CTX-1 concentrations ( $r = 0.670$ ,  $p = 0.009$ )<sup>26</sup>, but not with OPG<sup>26</sup>, ALP<sup>26</sup>, PIIINP<sup>29</sup>, or OC<sup>26,28</sup>.

Chandran, *et al* demonstrated a positive correlation

between C1-2C and both tender joint counts and swollen joint counts<sup>10</sup>. However,  $p$  values, Spearman rho correlation coefficients, and tender or swollen joint counts per unit increase in C1-2C were not stated. Grcevic, *et al* reported a positive association between BMP-4 and both patient global assessment of disease ( $r = 0.54$ ,  $p = 0.02$ ) and pain score on a visual analog scale ( $r = 0.49$ ,  $p = 0.04$ )<sup>23</sup>. No such associations were found between the same variables and either BMP-2 or BMP-6<sup>23</sup>.

*Association of biomarkers levels with laboratory variables.* An association was demonstrated between CRP levels and both CTX-1<sup>26</sup> and TRAIL<sup>25</sup> in patients with PsA, but not with either MMP-3<sup>27</sup> or OPG<sup>25</sup>. Erythrocyte sedimentation rate (ESR) was positively associated with both CTX-1<sup>26</sup> and OPG<sup>25</sup>. TRAIL was not associated with ESR levels<sup>25</sup>. Two studies consistently showed ALP to be positively associated with OC<sup>28,30</sup>. Serum creatinine levels were not associated with DKK-1, RANKL, M-CSF, or OPG levels in the single study that tested for this correlation<sup>11</sup>.

*Association of biomarkers levels with composite indices.* Franck and Ittel reported an association between disease activity and both ALP (mean serum concentration in patients

Table 2. Comparison of biomarkers levels in PsA cases vs healthy controls.

Domain	Biomarker	Reference	PsA vs HC	Sample Size, HC, PsA, PsC	OR	95% CI	p	Mean Serum Concentration	Units for Serum Concentration
Bone resorption markers									
MMP-3	Chandran 2010		Higher	26, 26, 26	1.403	1.121–1.175	0.003	25.8 vs 8.8	ng/ml
	Ribbens 2002		Higher (in females)	96, 18, 0			< 0.05	29.5 vs 9.1	ng/ml
	Ribbens 2002		Higher (in males)	96, 18, 0			< 0.05	39.5 vs 19.2	ng/ml
	Shibata 2009		Higher	11, 16, 15	14.9	1.9–397.4	< 0.01	OR of levels above cutoff	ng/ml
DKK-1	Dalbeth 2010		Higher	12, 38, 10			< 0.01	Charted	pg/ml
RANKL	Chandran 2010		Higher	26, 26, 26	1.006	1.000–1.012	0.04	319.8 vs 266.4	pg/l
	Dalbeth 2010		Equal	12, 38, 10			> 0.05	Charted	pmol/l
M-CSF	Dalbeth 2010		Higher	12, 38, 10			< 0.01	Charted	pg/ml
CTX-1	Grisar 2002		Higher	41, 23, 0			< 0.0001	4.8 vs 3.3	ng/ml
Bone formation markers									
OPG	Chandran 2010		Higher	26, 26, 26	1.014	1.004–1.024	0.01	663.8 vs 600.2	pg/ml
	Grisar 2002		Higher	41, 23, 0			< 0.05	47.5 vs 35.2	ng/ml
	Hofbauer 2006		Higher (in females)	90, 116, 0			< 0.05	6.7 vs 5.4	pmol/l
	Hofbauer 2006		Equal (males)	90, 116, 0			0.38	5.09 vs 5.4	pmol/l
	Dalbeth 2010		Equal	12, 38, 10			> 0.05	Charted	pg/ml
BMP-2	Grcevic 2010		Equal	25, 23, 0			> 0.05	NS	NS
BMP-4	Grcevic 2010		Equal	25, 23, 0			> 0.05	NS	NS
BMP-6	Grcevic 2010		Equal	25, 23, 0			> 0.05	NS	NS
ALP	Grisar 2002		Higher	41, 23, 0			< 0.05	12.5 vs 10.1	ng/ml
	Franck 2000		Lower (in females)	50, 32, 17			< 0.05	91 vs 125	U/l
	Franck 2000		Equal (males)	50, 32, 17			> 0.05	136 vs 125	U/l
	OC	Grisar 2002		Equal	41, 23, 0			> 0.05	20.7 vs 17.8
PIIINP	Magaro 1989		Equal	25, 25, 0			> 0.05	4.83 vs 7.25	ng/ml
	Franck 2000		Equal	50, 32, 17			NS	3.0 vs 3.6	ng/ml
	Franck 2000		Lower (in females)	50, 32, 17			< 0.05	2.28 vs 4.11	ng/ml
	Sharif 1996		Equal	16, 12, 0			0.079	0.39 vs 0.30	U/ml
Cartilage turnover markers									
COMP	Chandran 2010		Equal	26, 26, 26	1.000	0.999–1.002	0.47	2325.1 vs 1669.7	ng/ml
	Shibata 2009		Higher	11, 16, 15			< 0.01	12.7 vs 8.9	U/l
C1-2C	Chandran 2010		Equal	26, 26, 26	0.462	0.001–217.738	0.81	0.6 vs 0.5	mcg/ml
CPII:C2C	Chandran 2010		Equal	26, 26, 26	2.170	0.585–8.044	0.23	4.76 vs 3.70	No units (ratio)
Synovial integrity marker									
TRAIL	Hofbauer 2006		Higher	90, 116, 0			< 0.01	66.1 vs 50	pg/ml

PsA: psoriatic arthritis; HC: healthy control; PsC: cutaneous psoriasis without arthritis; MMP-3: matrix metalloproteinase-3; DKK-1: Dickkopf-1; RANKL: receptor activator of nuclear factor- $\kappa$ B ligand; M-CSF: macrophage colony-stimulating factor; CTX-1: crosslinked telopeptide of collagen-1; OPG: osteoprotegerin; BMP: bone morphogenetic protein; ALP: bone alkaline phosphatase; OC: osteocalcin; PIIINP: amino-terminal propeptide of procollagen type III; COMP: cartilage oligomeric matrix protein; TRAIL: tumor necrosis factor-related apoptosis-inducing ligand; NS: not stated; C1-2C: a neoepitope released when type 2 cartilage is degraded by collagenases; CPII:C2C: ratio of cartilage degradation vs byproduct formation.

with “no disease activity” 69 U/l vs 148 U/l in patients with “high” disease activity,  $p < 0.005$ ) and OC (mean serum concentration in patients with “no disease activity” 2.2 ng/ml vs 3.92 ng/ml in patients with “high” disease activity,

Table 3. Comparison of biomarkers levels in PsA cases vs PsC.

Domain	Biomarker	Reference	PsA vs PsC	Sample Size, HC, PsA, PsC	OR	95% CI	p	Mean Serum Concentration	Units for Serum Concentration
Bone resorption markers									
MMP-3									
		Chandran 2010	Higher	26, 26, 26	1.275	1.018–1.597	0.03	25.8 vs. 11.3	ng/ml
		Shibata 2009	Higher	11, 16, 15	6.3	1.3–37.8	< 0.01	OR of levels above cutoff	ng/ml
DKK-1									
		Dalbeth 2010	Higher	12, 38, 10			< 0.001	Charted	pg/ml
		Dalbeth 2010	Higher (in erosive)	12, 38, 10			< 0.001	Charted	pg/ml
		Dalbeth 2010	Higher (in non-erosive)	12, 38, 10			< 0.05	Charted	pg/ml
RANKL									
		Chandran 2010	Equal	26, 26, 26	0.999	0.994–1.004	0.77	319.8 vs 319.8	pg/l
		Dalbeth 2010	Equal	12, 38, 10			> 0.05	Charted	pmol/l
		Dalbeth 2010	Equal (if erosive)	12, 38, 10			> 0.05	Charted	pmol/l
		Dalbeth 2010	Equal (if non-erosive)	12, 38, 10			> 0.05	Charted	pmol/l
M-CSF									
		Dalbeth 2010	Higher	12, 38, 10			< 0.01	Charted	pg/ml
		Dalbeth 2010	Higher (erosive)	12, 38, 10			< 0.001	Charted	pg/ml
		Dalbeth 2010	Equal (non-erosive)	12, 38, 10			> 0.05	Charted	pg/ml
Bone formation marker									
OPG									
		Chandran 2010	Higher	26, 26, 26	1.011	1.002–1.021	0.02	663.8 vs 595.5	pg/ml
		Dalbeth 2010	Equal	12, 38, 10			> 0.05	Charted	pg/ml
		Dalbeth 2010	Equal (if erosive)	12, 38, 10			> 0.05	Charted	pg/ml
		Dalbeth 2010	Equal (if non-erosive)	12, 38, 10			> 0.05	Charted	pg/ml
OC									
		Franck 2000	Lower (in females)	50, 32, 17			< 0.05	2.28 vs 3.0	ng/ml
Cartilage turnover marker									
COMP									
		Chandran 2010	Equal	26, 26, 26	1.000	0.999–1.001	0.35	2325.1 vs 2516.5	ng/ml
		C1-2C	Equal	26, 26, 26	0.021	< 0.001–16.442	0.26	0.6 vs 0.5	mcg/ml
		CPII:C2C	Higher	26, 26, 26	4.762	1.352–16.767	0.02	4.76 vs 3.28	No units (ratio)

PsA: psoriatic arthritis; PsC: cutaneous psoriasis without arthritis; HC: healthy control; MMP-3: matrix metalloproteinase-3; DKK-1: Dickkopf-1; RANKL: receptor activator of nuclear factor- $\kappa$ B ligand; M-CSF: macrophage colony-stimulating factor; OPG: osteoprotegerin; OC: osteocalcin; COMP: cartilage oligomeric matrix protein; C1-2C: a neopeptide released when type 2 cartilage is degraded by collagenases; CPII:C2C: ratio of cartilage degradation vs byproduct formation.

$p < 0.05$ ), although the numbers of patients in these groups were very small (4 vs 98, respectively) and no definition of “no” versus “high” disease activity was stated<sup>28</sup>. Disease Activity Score at 28 joints using CRP (DAS28-CRP) was not associated with DKK-1, M-CSF, RANKL, OPG<sup>11</sup>, BMP-2, BMP-4, or BMP-6<sup>23</sup>. BMP-4 was associated with BASDAI in the 1 study that tested this correlation ( $r = 0.46$ ,  $p = 0.04$ )<sup>23</sup>. No association was demonstrated between BASDAI and either BMP-2 or BMP-6<sup>23</sup>. COMP positively correlated with the Psoriasis Area and Severity Index (PASI) in 1 study (analyses not stated in paper)<sup>10</sup>. No association was demonstrated between DAS28-CRP and DKK-1, M-CSF, RANKL, OPG, BMP-2, BMP-4, or BMP-6<sup>11</sup>. No association was demonstrated between BASFI and BMP-2, BMP-4, or BMP-6<sup>23</sup>.

*Association of biomarkers levels with radiographic variables.* Four studies<sup>10,11,23,25</sup> investigated the association between biomarker levels and radiographic variables, with 2 studies providing the majority of the data<sup>10,11</sup> (Table 4).

Joint space narrowing was associated with RANKL ( $p < 0.05$ ) and M-CSF ( $p < 0.01$ ), but not with DKK-1 or OPG in the 1 study testing these associations<sup>11</sup>. Similarly, osteolysis (defined as pencil-in-cup deformity) was associated with both RANKL ( $p < 0.05$ ) and M-CSF ( $p < 0.05$ ), but not with DKK-1 or OPG in the 1 study testing these associations<sup>11</sup>. Osteoproliferation was not associated with RANKL, M-CSF, DKK-1, or OPG in the 1 study testing these associations<sup>11</sup>. Two studies tested for association between peripheral radiographic erosions and serum biomarkers. M-CSF was positively associated with peripheral erosions ( $p < 0.001$ )<sup>11</sup>, but the remaining biomarkers were not (MMP-3, DKK-1, RANKL, OPG, COMP, C2C, C1-2C, CPII)<sup>10,11</sup>. The modified van der Heijde score for PsA (VDH) is a composite score encompassing joint space narrowing and erosions in peripheral radiographs<sup>31</sup>. Dalbeth, *et al* demonstrated an association between the VDH and both M-CSF ( $p < 0.01$ ) and RANKL ( $p < 0.05$ ), but not with DKK-1 or OPG<sup>11</sup>.

Table 4. Association of biomarkers levels with radiographic variables.

Variable	Biomarker	Reference	Association	Sample Size, HC, PsA, PsC	Spearman Rho, r	95% CI	p	Units for Serum Concentration
VDH composite score	M-CSF	Dalbeth 2010	Yes	12, 38, 10			< 0.01	pg/ml
	RANKL	Dalbeth 2010	Yes	12, 38, 10			< 0.05	pmol/l
	DKK-1	Dalbeth 2010	No	12, 38, 10			> 0.05	pg/ml
	OPG	Dalbeth 2010	No	12, 38, 10			> 0.05	pg/ml
Joint space narrowing	RANKL	Dalbeth 2010	Yes	12, 38, 10			< 0.05	pmol/l
	M-CSF	Dalbeth 2010	Yes	12, 38, 10			< 0.01	pg/ml
	DKK-1	Dalbeth 2010	No	12, 38, 10			> 0.05	pg/ml
	OPG	Dalbeth 2010	No	12, 38, 10			> 0.05	pg/ml
Peripheral erosions	M-CSF	Dalbeth 2010	Yes	12, 38, 10		Charted	< 0.001	pg/ml
	MMP-3	Chandran 2010	No	26, 26, 26			NS	ng/ml
	DKK-1	Dalbeth 2010	No	12, 38, 10		Charted	> 0.05	pg/ml
	RANKL	Chandran 2010	No	26, 26, 26			NS	pg/l
	RANKL	Dalbeth 2010	No	12, 38, 10		Charted	> 0.05	pmol/l
	OPG	Chandran 2010	No	26, 26, 26			NS	pg/ml
	OPG	Dalbeth 2010	No	12, 38, 10		Charted	> 0.05	pg/ml
	COMP	Chandran 2010	No	26, 26, 26			NS	ng/ml
	C2C	Chandran 2010	No	26, 26, 26			NS	ng/ml
	C1-2C	Chandran 2010	No	26, 26, 26			NS	mcg/ml
CPII	Chandran 2010	No	26, 26, 26			NS	Ratio	
Osteolysis	RANKL	Dalbeth 2010	Yes	12, 38, 10			< 0.05	pmol/l
	M-CSF	Dalbeth 2010	Yes	12, 38, 10			< 0.05	pg/ml
	DKK-1	Dalbeth 2010	No	12, 38, 10			> 0.05	pg/ml
	OPG	Dalbeth 2010	No	12, 38, 10			> 0.05	pg/ml
Osteoproliferation	DKK-1	Dalbeth 2010	No	12, 38, 10			> 0.05	pg/ml
	RANKL	Dalbeth 2010	No	12, 38, 10			> 0.05	pmol/l
	M-CSF	Dalbeth 2010	No	12, 38, 10			> 0.05	pg/ml
	OPG	Dalbeth 2010	No	12, 38, 10			> 0.05	pg/ml
Sacroiliitis	MMP-3	Chandran 2010	No	26, 26, 26			NS	ng/ml
	RANKL	Chandran 2010	No	26, 26, 26			NS	pg/l
	RANKL	Dalbeth 2010	Uncertain	12, 38, 10			NS	pmol/l
	OPG	Chandran 2010	No	26, 26, 26			NS	pg/ml
	OPG	Dalbeth 2010	Uncertain	12, 38, 10			NS	pg/ml
	BMP-2	Grcevic 2010	No	25, 23, 0			NS	NS
	BMP-4	Grcevic 2010	No	25, 23, 0			NS	NS
	BMP-6	Grcevic 2010	No	25, 23, 0			NS	NS
	COMP	Chandran 2010	No	26, 26, 26			NS	ng/ml
	C2C	Chandran 2010	No	26, 26, 26			NS	ng/ml
C1-2C	Chandran 2010	No	26, 26, 26			NS	mcg/ml	
CPII	Chandran 2010	No	26, 26, 26			NS	Ratio	
BMD hip	DKK-1	Dalbeth 2010	Uncertain	12, 38, 10			NS	pg/ml
	M-CSF	Dalbeth 2010	Uncertain	12, 38, 10			NS	pg/ml
	DKK-1	Dalbeth 2010	No	12, 38, 10			> 0.05	pg/ml
	RANKL	Dalbeth 2010	No	12, 38, 10			> 0.05	pmol/l
BMD lumbar spine	M-CSF	Dalbeth 2010	No	12, 38, 10			> 0.05	pg/ml
	OPG	Dalbeth 2010	No	12, 38, 10			> 0.05	pg/ml
	OPG	Hofbauer 2006	No	90, 116, 0	0.046		0.62	pmol/l
BMD femur	TRAIL	Hofbauer 2006	No	90, 116, 0	0.142		0.13	pg/ml
	OPG	Hofbauer 2006	No	90, 116, 0	0.033		0.72	pmol/l
	TRAIL	Hofbauer 2006	No	90, 116, 0	0.089		0.34	pg/ml

HC: healthy control; PsA: psoriatic arthritis; PsC: cutaneous psoriasis without arthritis; VDH: van der Heijde score for PsA; M-CSF: macrophage colony-stimulating factor; RANKL: receptor activator of nuclear factor- $\kappa$ B ligand; DKK-1: Dickkopf-1; OPG: osteoprotegerin; MMP-3: matrix metalloproteinase-3; COMP: cartilage oligomeric matrix protein; BMP: bone morphogenetic protein; TRAIL: tumor necrosis factor-related apoptosis-inducing ligand; BMD: bone mineral density; NS: not stated; C1-2C: a neoepitope released when type 2 cartilage is degraded by collagenases; CPII:C2C: ratio of cartilage degradation vs byproduct formation.

Three studies<sup>10,11,23</sup> tested for association between radiographic sacroiliitis and several biomarkers; no associations were found with MMP-3, RANKL, OPG, BMP-2, BMP-4, BMP-6, COMP, C2C, C1-2C, and CPII, and results were equivocal for DKK-1 and M-CSF<sup>10,11,23</sup>.

No association was found between BMD at the hip, lumbar spine or femur, and several biomarkers, including DKK-1, RANKL, M-CSF, OPG, or TRAIL (Table 4)<sup>25</sup>.

## DISCUSSION

A summary of biomarkers that are associated with PsA and its clinical variables is shown in Figure 2. The following biomarkers were associated with PsA: MMP-3, DKK-1, M-CSF, CTX-1, and TRAIL, and the results were equivocal for OPG and ALP. MMP-3, DKK-1, M-CSF, CPII:C2C, and possibly OPG were associated with PsA independently of PsC. ALP was associated with male sex in PsA. CTX-1 was associated with disease duration, C1-2C with both tender and swollen joint counts, and BMP-4 with both patient global assessment of disease and pain score. CRP was associated with both CTX-1 and TRAIL, ESR with both CTX-1 and OPG, and ALP with OC. Disease activity was associated with ALP and possibly OC, BASDAI was associated with BMP-4, and skin score (PASI) correlated with COMP. The following biomarkers were associated with radiographic features: M-CSF with the PsA-modified VDH composite score, joint space narrowing, peripheral radio-

graphic erosions, and osteolysis; RANKL with the VDH composite score, joint space narrowing, and osteolysis.

*Disparity in study findings.* There are several potential reasons for disparity in study results. First, most of the studies have been cross-sectional rather than prospectively conducted cohort studies. A study by Young-Min, *et al* of early rheumatoid arthritis (RA) demonstrated that biomarkers are associated with swollen/tender joint counts and DAS only when longitudinal data were analyzed and not when cross-sectional baseline data were analyzed<sup>32</sup>. Studies have investigated differing clinical variables and used differing collection protocols (overnight fasted in 2 studies<sup>25,30</sup>) and laboratory techniques, making comparison difficult. Several studies have small samples<sup>23,24,26,29,30,33</sup>, and likely were underpowered.

We acknowledge that there may be publication bias toward studies with positive results. However, we suspect that because of several biomarkers being reported in each study, with a mixture of both positive and negative findings, that selective reporting bias may be less of a problem.

While it is common practice in studies of metabolic bone disease to test bone markers in the morning and in a fasted state, few PsA studies have undertaken testing in this manner. Clowes, *et al* investigated the effect of feeding versus fasting on several markers in 20 women and demonstrated little effect on bone biomarkers, except in the case of serum CTX<sup>34</sup>. Other factors influencing serum levels were

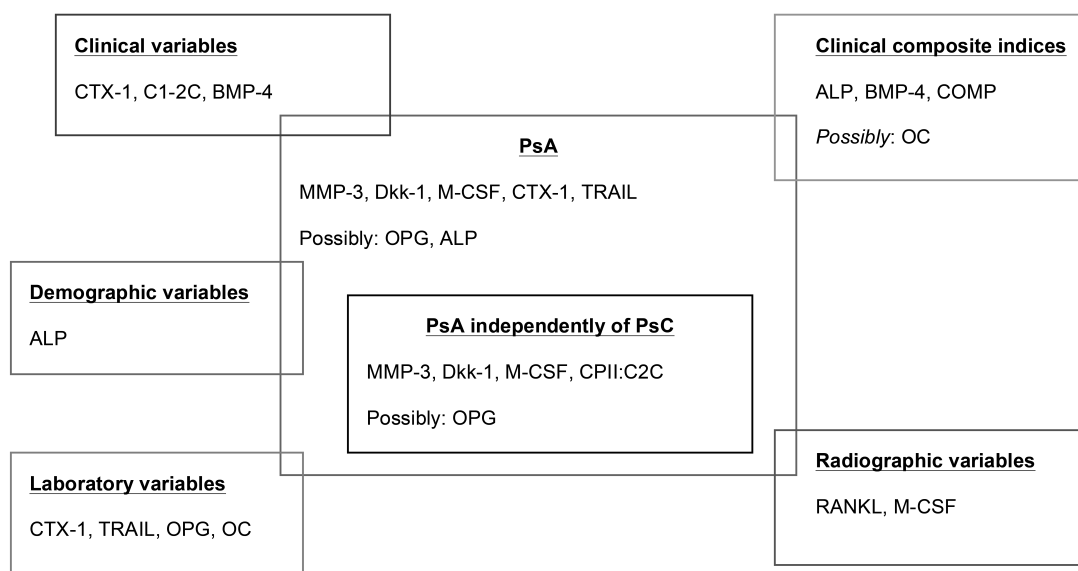

Figure 2. Summary of serum soluble bone and cartilage turnover biomarkers showing association with psoriatic arthritis. CTX-1: crosslinked telopeptide of collagen-1; BMP-4: bone morphogenetic protein-4; C1-2C: a neoepitope released when type 2 cartilage is degraded by collagenases; ALP: bone alkaline phosphatase; TRAIL: tumor necrosis factor-related apoptosis-inducing ligand; OPG: osteoprotegerin; OC: osteocalcin; MMP-3: matrix metalloproteinase-3; DKK-1: Dickkopf-1; M-CSF: macrophage colony-stimulating factor; COMP: cartilage oligomeric matrix protein; RANKL: receptor activator of nuclear factor- $\kappa$ B ligand; PsA: psoriatic arthritis; CPII:C2C: ratio of cartilage degradation vs byproduct formation.



circadian rhythm<sup>35</sup>, sex, oral contraceptive pill use, menstrual cycle, growth, diet, meal composition, and timing of sample after ingestion<sup>34</sup>.

Standardization of diet prior to sampling may improve measurement variability, but at the expense of feasibility.

Conflicting reports of associations between serum biomarker concentrations and demographic variables may be, in part, attributable to uncontrolled confounding because of a lack of matching or adequate adjustment for age and sex within the study design and analysis. Dalbeth, *et al* did not adjust for the higher proportion of women in their HC versus PsA group<sup>11</sup>. Hofbauer, *et al* had entirely men in its HC group, because this was a “convenience sample” derived from participants in a coronary artery study<sup>25</sup>. They also reported higher OPG serum concentration in women compared with men, because of a lack of adjustment for sex; estrogen is known to stimulate OPG production<sup>24</sup>. Ribbens, *et al* sex-matched their participants, and because corticosteroid use alters MMP-3 levels, analyses were made only in patients not treated with corticosteroids<sup>33</sup>.

Sharif, *et al* did not state the source of their HC group, which appears much younger than the PsA cohort<sup>29</sup>. Significant differences in mean age, sex, and disease duration of the patients in all 3 disease groups were noted. While Shibata, *et al*<sup>24</sup> matched for age in their study, further inspection demonstrates that the HC group was much younger than both the PsA and PsC groups<sup>24</sup>.

*Priorities for future research.* Biomarker identification in PsA may help identify patients with PsC with subclinical arthritis and aid both prognostication and stratified medicine approaches. Biomarkers may facilitate monitoring of disease activity and treatment response, so that nonefficacious treatment is switched rather than waiting several years for radiographic progression. Our knowledge of the pathogenesis of PsA, and how it overlaps with ankylosing spondylitis and RA, may be improved through such research. Biomarkers may guide the development of new drugs, both to obtain proof of principle in an early stage of drug development and avoid reliance on slow structural damage outcomes requiring lengthy clinical trials<sup>22</sup>. Serum biomarkers may offer a more economic and readily available alternative to imaging. All such knowledge is important for the individual patient, public health, and health policy.

Despite the theoretical advantages, “novel” biochemical markers have not translated to the bedside. This may be in part attributable to a lack of longitudinal prospective studies and robust evidence of superiority over existing biomarkers, e.g., CRP. PsA is a heterogeneous disease with several subphenotypes, varied clinical course, and often comorbidities that can confound the interpretation of results<sup>36</sup>.

There is a need for longitudinal studies to identify biomarkers that correlate with or predict longterm clinical, radiographic, and functional outcomes, and treatment

response. Research will be most valuable if it identifies biomarkers that fulfill the Outcome Measures in Rheumatology Clinical Trials filter: truth, discrimination, and feasibility<sup>37</sup>. It is likely that a panel of biomarkers, rather than a single biomarker, will achieve this<sup>12,38</sup>.

## ACKNOWLEDGMENT

We thank Dr. Vinod Chandran (VC) and Professor Oliver Fitzgerald (OF) for providing their expert input to ensure no important articles were omitted during the systematic search. We thank Jason Ovens (Head of Library and Knowledge Services at the Royal United Hospital, Bath) for facilitating the systematic search and sourcing articles.

## REFERENCES

1. Frediani B, Allegri A, Falsetti P, Storri L, Bisogno S, Baldi F, et al. Bone mineral density in patients with psoriatic arthritis. *J Rheumatol* 2001;28:138-43.
2. Vincenti MP, Clark IM, Brinckerhoff CE. Using inhibitors of metalloproteinases to treat arthritis. Easier said than done? *Arthritis Rheum* 1994;37:1115-26.
3. Poole AR. Biochemical/immunochemical biomarkers of osteoarthritis: utility for prediction of incident or progressive osteoarthritis. *Rheum Dis Clin North Am* 2003;29:803-18.
4. Liberati A, Altman DG, Tetzlaff J, Mulrow C, Gotzsche PC, Ioannidis JP, et al. The PRISMA statement for reporting systematic reviews and meta-analyses of studies that evaluate health care interventions: explanation and elaboration. *PLoS Medicine* 2009;6:1-28.
5. Taylor W, Gladman D, Helliwell P, Marchesoni A, Mease P, Mielants H, et al. Classification criteria for psoriatic arthritis: Development of new criteria from a large international study. *Arthritis Rheum* 2006;54:2665-73.
6. Moll J, Wright V. Psoriatic arthritis. *Semin Arthritis Rheum* 1973;3:55-78.
7. Sieper J, Rudwaleit M, Baraliakos X, Brandt J, Braun J, Burgos-Vargas R, et al. The Assessment of SpondyloArthritis International Society (ASAS) handbook: a guide to assess spondyloarthritis. *Ann Rheum Dis* 2009;68 Suppl 2:ii1-44.
8. Szentpetery A, McKenna MJ, Murray BF, Ng CT, Brady JJ, Morrin M, et al. Periarticular bone gain at proximal interphalangeal joints and changes in bone turnover markers in response to tumor necrosis factor inhibitors in rheumatoid and psoriatic arthritis. *J Rheumatol* 2013;40:653-62.
9. Wagner CL, Visvanathan S, Elashoff M, McInnes IB, Mease PJ, Krueger GG, et al. Markers of inflammation and bone remodelling associated with improvement in clinical response measures in psoriatic arthritis patients treated with golimumab. *Ann Rheum Dis* 2013;72:83-8.
10. Chandran V, Cook RJ, Edwin J, Shen H, Pellett FJ, Shanmugarajah S, et al. Soluble biomarkers differentiate patients with psoriatic arthritis from those with psoriasis without arthritis. *Rheumatology* 2010;49:1399-405.
11. Dalbeth N, Pool B, Smith T, Callon KE, Lobo M, Taylor WJ, et al. Circulating mediators of bone remodeling in psoriatic arthritis: implications for disordered osteoclastogenesis and bone erosion. *Arthritis Res Ther* 2010;12:R164.
12. Mullan RH, Matthews C, Bresnihan B, FitzGerald O, King L, Poole AR, et al. Early changes in serum type II collagen biomarkers predict radiographic progression at one year in inflammatory arthritis patients after biologic therapy. *Arthritis Rheum* 2007;56:2919-28.
13. Critical appraisal skills programme: making sense of evidence. 11 questions to help you make sense of a case control study. [Internet. Accessed September 30, 2014.] Available from:

- calder.med.miami.edu/portals/ebmfiles/UM%20CASP%20Case-Controls%20Assessment%20Tool.pdf
14. Ciacli C, Pușchiță M, Drugărin D, Solovan C, Gurban CV, Cotoraci C. [Bone turnover markers evaluation in psoriatic arthritis]. [Article in Romanian] *Rev Med Chir Soc Med Nat Iasi* 2008;112:635-40.
  15. Ciacli C, Pușchiță M. RANKL/RANK/OPG molecular complex—control factors in bone remodeling in psoriatic arthritis. *Rev Med Chir Soc Med Nat Iasi* 2011;115:354-60.
  16. Borman P, Babaoglu S, Gur G, Bingol S, Bodur H. Bone mineral density and bone turnover in patients with psoriatic arthritis. *Clin Rheumatol* 2008;27:443-7.
  17. Skoumal M, Haberhauer G, Fink A, Steiner A, Klingler A, Varga F, et al. Increased serum levels of cartilage oligomeric matrix protein in patients with psoriasis vulgaris: a marker for unknown peripheral joint involvement? *Clin Exp Rheumatol* 2008;26:1087-90.
  18. Fraser A, Fearon U, Billinghurst RC, Ionescu M, Reece R, Barwick T, et al. Turnover of type II collagen and aggrecan in cartilage matrix at the onset of inflammatory arthritis in humans: relationship to mediators of systemic and local inflammation. *Arthritis Rheum* 2003;48:3085-95.
  19. Lata S, Cuchacovich R, Hagan J, Patel N, Espinoza LR. Do adipocytokines play a role in bone turnover in spondyloarthropathies? *J Invest Med* 2010;58:443.
  20. Pedersen SJ, Hetland ML, Sørensen IJ, Ostergaard M, Nielsen HJ, Johansen JS. Circulating levels of interleukin-6, vascular endothelial growth factor, YKL-40, matrix metalloproteinase-3, and total aggrecan in spondyloarthritis patients during 3 years of treatment with TNF $\alpha$  inhibitors. *Clinical Rheumatol* 2010;29:1301-9.
  21. Cauza E, Hanusch-Enserer U, Frischmuth K, Fabian B, Dunky A, Kostner K. Short-term infliximab therapy improves symptoms of psoriatic arthritis and decreases concentrations of cartilage oligomeric matrix protein. *J Clin Pharm Ther* 2006;31:149-52.
  22. van Kuijk AW, DeGroot J, Koeman RC, Sakkee N, Baeten DL, Gerlag DM, et al. Soluble biomarkers of cartilage and bone metabolism in early proof of concept trials in psoriatic arthritis: effects of adalimumab versus placebo. *PLoS One* 2010;5:e12556.
  23. Grcevic D, Jajic Z, Kovacic N, Lukic IK, Velagic V, Grubisic F, et al. Peripheral blood expression profiles of bone morphogenetic proteins, tumor necrosis factor-superfamily molecules, and transcription factor Runx2 could be used as markers of the form of arthritis, disease activity, and therapeutic responsiveness. *J Rheumatol* 2010;37:246-56.
  24. Shibata S, Tada Y, Komine M, Hattori N, Osame S, Kanda N, et al. Anti-cyclic citrullinated peptide antibodies and IL-23p19 in psoriatic arthritis. *J Dermatol Sci* 2009;53:34-9.
  25. Hofbauer LC, Schoppet M, Christ M, Teichmann J, Lange U. Tumour necrosis factor-related apoptosis-inducing ligand and osteoprotegerin serum levels in psoriatic arthritis. *Rheumatology* 2006;45:1218-22.
  26. Grisar J, Bernecker PM, Aringer M, Redlich K, Sedlak M, Wolozczuk W, et al. Ankylosing spondylitis, psoriatic arthritis, and reactive arthritis show increased bone resorption, but differ with regard to bone formation. *J Rheumatol* 2002;29:1430-6.
  27. Ribbens C, Andre B, Jaspas JM, Kaye O, Kaiser MJ, De Groot D, et al. Matrix metalloproteinase-3 serum levels are correlated with disease activity and predict clinical response in rheumatoid arthritis. *J Rheumatol* 2000;27:888-93.
  28. Franck H, Ittel T. Serum osteocalcin levels in patients with psoriatic arthritis: an extended report. *Rheumatol Int* 2000;19:161-4.
  29. Sharif M, George E, Dieppe PA. Synovial fluid and serum concentrations of aminoterminal propeptide of type III procollagen in healthy volunteers and patients with joint disease. *Ann Rheum Dis* 1996;55:47-51.
  30. Magaro M, Altomonte L, Mirone L, Zoli A, Tricerri A. Serum osteocalcin as an index of bone turnover in active rheumatoid arthritis and in active psoriatic arthritis. *Clin Rheumatol* 1989;8:494-8.
  31. van der Heijde D, Sharp J, Wassenberg S, Gladman DD. Psoriatic arthritis imaging: a review of scoring methods. *Ann Rheum Dis* 2005;64 Suppl 2:ii61-4.
  32. Young-Min S, Cawston T, Marshall N, Coady D, Christgau S, Saxne T, et al. Biomarkers predict radiographic progression in early rheumatoid arthritis and perform well compared with traditional markers. *Arthritis Rheum* 2007;56:3236-47.
  33. Ribbens C, Martin y Porras M, Franchimont N, Kaiser MJ, Jaspas JM, Damas P, et al. Increased matrix metalloproteinase-3 serum levels in rheumatic diseases: relationship with synovitis and steroid treatment. *Ann Rheum Dis* 2002;61:161-6.
  34. Clowes JA, Hannon RA, Yap TS, Hoyle NR, Blumsohn A, Eastell R. Effect of feeding on bone turnover markers and its impact on biological variability of measurements. *Bone* 2002;30:886-90.
  35. Schlemmer A, Hassager C. Acute fasting diminishes the circadian rhythm of biochemical markers of bone resorption. *Euro J Endocrinol* 1999;140:332-7.
  36. Ritchlin C. Biomarker development in psoriatic arthritis. *J Rheumatol Suppl.* 2012 July;89:57-60.
  37. Boers M, Brooks P, Strand CV, Tugwell P. The OMERACT filter for Outcome Measures in Rheumatology. *J Rheumatol* 1998;25:198-9.
  38. Chandran V. Soluble biomarkers may differentiate psoriasis from psoriatic arthritis. *J Rheumatol Suppl.* 2012 July;89:65-6.